



STANZEN



BOHREN



HEBEN



SÄGEN



ENTGRATEN

# *Ersatzteilliste/ ab 1712F0878*

## *liste d pièces détachées*

**ALFRA ROTABEST RB 50 SP**

- DE** Metallkernbohrmaschine
- EN** Metal Core Drilling Machine
- FR** Perceuse à socle magnétique
- ES** Taladro magnético

Art.-Nr. 18850 / Prod.-No. 18850 / Art.-n° 18850 / N° de producto 18850



**Explosionszeichnung RB 50SP / Exploded drawing RB 50SP / Vue éclatée RB 50SP / Despiece RB 50SP**

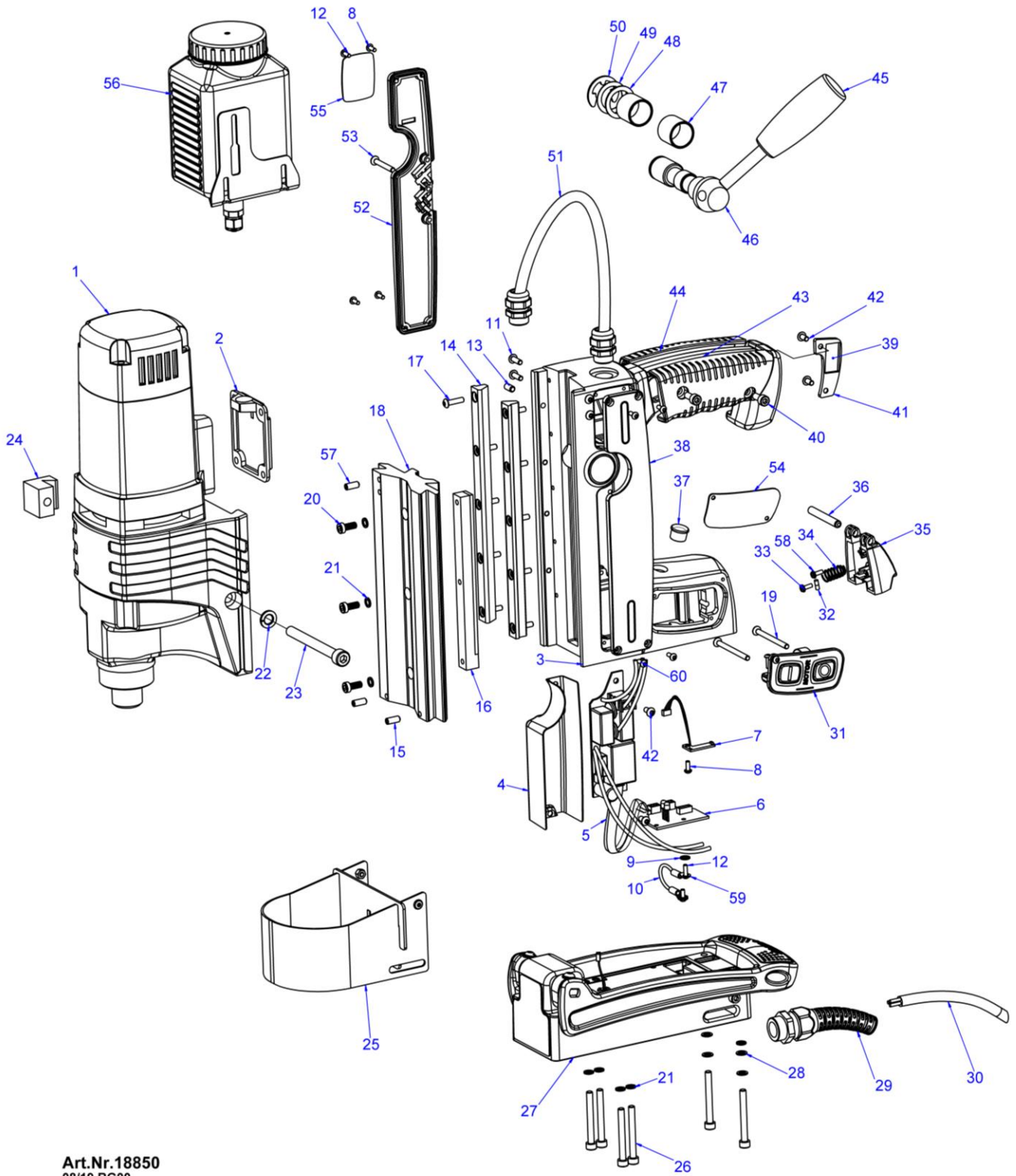

Art.Nr.18850  
08/19 RG00

## Ersatzteile RB 50SP / Spare parts RB 50SP / Pièces de rechange RB 50SP / Piezas de repuesto RB 50SP

Pos.	Qty.	Prod.-Nr.	Beschreibung	Description	Descripción
1	1	18045	Motor AHB20/2 230V	Motor AHB20/2 230V	Motor AHB20/2 230V
2	1	189501077	EHN Flanschstück	Flange piece EHN	Pieza de brida EHN
3	1	189414093	Ständergehäuse RB 35SP RAL 2004	housing 35 SP RAL 2004	carcasa 35 SP RAL 2004
4	1	189414285	Isoliereinlage	insulating insert	inserto aislante
5	1	189414163	Leiterplatte 230 Volt Relais	PCB 230 volt relay	PCB relé de 230 voltios
6	1	189414162	Leiterplatte CPU	PCB CPU	PCB CPU
7	1	189414164	Leiterplatte Sensor	PCB sensor	PCB sensor
8	11	ISO7380-M3X8-10.9	Flachrundschraube	round head screw	tornillos de cabeza redonda
9	3	DIN6798-A4,3FST	Fächerscheibe	Serrated washer	arandela dentada
10	1	3063	Kabel 1x0,82	cable 1x0,82	Cable 1x0,82
11	2	ISO7380-M4X12-10.9	Flachrundschrauben	round head screw	tornillos de cabeza redonda
12	2	ISO7380-M3x10	Flachrundschraube	round head screw	tornillos de cabeza redonda
13	4	DIN913-M5X8-45H-TF	Gewindestift	set screw	espiga roscada
14	2	189412104	Profilführung	profile guide	perfil
15	2	DIN913-M5X12-45H	Gewindestift	set screw	espiga roscada
16	1	189301003	Zahnstange	rack	cremallera
17	10	ISO7380-M4X16-10.9	Flachrundschraube	round head screw	tornillos de cabeza redonda
18	1	189414040	Schlitten	slide	carro -negro-
19	2	DIN7991-M4X55-A2	Senkschraube	countersunk head screw	tornillo avellanado
20	3	DIN6912-M5X16-8.8	Zylinderschraube	hexagon socket screw	tornillo cilíndrico
21	9	DIN7980-5-ST	Federring	spring washer	arandela de muelle
22	1	DIN7980-8-ST	Federring	spring washer	arandela de muelle
23	1	DIN912-M8X80-8.8	Zylinderschraube	hexagon socket screw	tornillo cilíndrico
24	1	189501076	Befestigungsstein	motor fixing block	pieza de sujeción
25	1	189414052	Schutzschild	safety guard	escudo de protección
26	6	DIN912-M5X45-8.8-A2R	Zylinderschraube	hexagon socket screw	tornillo cilíndrico
27	1	189414000	Schaltbarer Permanentmagnet	switchable permanent magnet	iman permanente commutable
28	2/2/2	DIN988-5x10x0,2/0,5/1	Passscheibe	washer	arandela
29	1	189414159	Kabelverschraubung	cable gland	prensaestopa
30	1	189412071	Kabel mit Stecker	mains cord with plug	cable con conector
31	1	189414161	Folientastatur ON/OFF	keypad ON/OFF	plástico plana ON/OFF
32	1	189414047	Stabmagnet	round magnet	barra magnética
33	1	W1451-M3X8-A2	Linsenkopfschraube	lens head screw	tornillo alomado
34	1	03191-021	Druckfeder	pressure spring	muelle de presión
35	1	189414087	Sicherheitslasche	safety tab	pletina de seguridad
36	1	DIN7-6M6X40	Zylinderstift	dowel pin	pasador cilíndrico
37	1	189412068	Stecklinse	lens	lente
38	1	189414075	Seitenblende -links-	side cover -left-	cobertura lateral -izquierda-
39	1	189414010-635N48	Magnet	Magnet	imán
40	4	DIN912-M5X12-8.8-A2R	Zylinderschraube	hexagon socket screw	tornillo cilíndrico
41	1	189414090	Einsatz für Magneten	magnet holder	inserto para iman
42	4	ISO7380-M4X8-10.9	Flachrundschraube	round head screw	tornillos de cabeza redonda
43	1	189414088.grey	Griffschale -links-	grip plate -left-	casquillo con asidero -izquierdo-

44	1	189414089.grey	Griffschale -rechts-	grip plate -right-	casquillo con asidero -derecho-
45	3	189301074	Speichen (kpl.)	spokes (compl.)	rayos del torniquete
46	1	189301015	Ritzelwelle	pinion shaft	árbol del piñón
47	2	189414034	Gleitlager	plain bearing	cojinete de deslizamiento
48	1	DIN988-20X28X0,5	Passscheibe	washer	arandela
49	1	DIN988-20X28X1,0	Passscheibe	washer	arandela
50	1	DIN6799-D15,0	Sicherungsscheibe	lock washer	anillo de seguridad
51	1	189414033	Kabel (kpl.)	cable (compl.)	cable (compl.)
52	1	189414072	Seitenblende -rechts-	side cover -right-	cobertura lateral -derecha-
53	1	DIN7991-M4x30-8.8SW	Senkschraube	countersunk head screw	tornillo avellanado
54	1	189414255	Typenschild	type plate	placa de características
55	1	189414039	Aufkleber „Alfra“ Doming	sticker “Alfra“	autocollant „Alfra“ Doming
56	1	189412029	Kühlmitteleinrichtung	coolant unit	recipiente del refrigerante
57	1	DIN915-M5x12-45H	Gewindestift	set screw	espiga roscada
58	1	W1451-M3x8-10.9-P3R	Torx-Schraube für Kunststoff	Torx screw for plastic	Tornillo torx para plástico
59	2	189-05589011	Ringzunge	ring tongue	lengua anillo
60	1	DIN7991-M3x6-8.8-A2R	Senkschraube	countersunk head screw	tornillo avellanado

**Explosionszeichnung Motor / Exploded drawing of the motor / Vue éclatée du moteur / Despiece del motor**

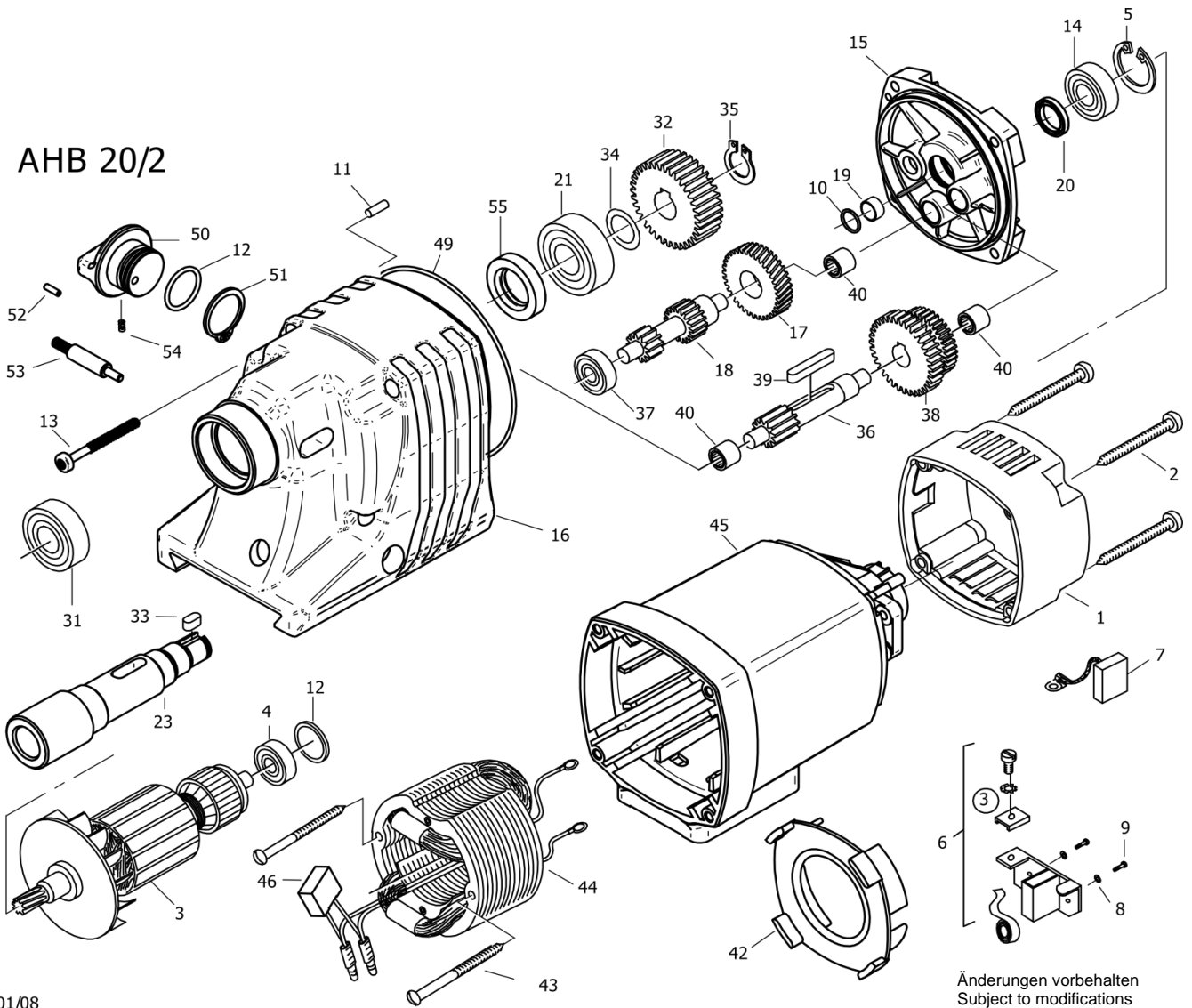

01/08

Änderungen vorbehalten  
 Subject to modifications  
 Sous réserve de modifications  
 Sin previo aviso

## Ersatzteile des Motors / Pièces de rechange du moteur / Piezas de repuesto del motor

Pos.	Qty.	Prod. No.	Beschreibung	Description
1	1	189502070	Motorkappe	cap for motor housing
2	4	189622018	Blechschaube	tapping screw
3	1	189502085	Anker	armature
4	1	189812011	Rillenkugellager	deep groove ball bearing
5	1	189601017	Sicherungsring	retaining ring
6	2	189502053	Kohlebürstenhalter	carbon brush holder
7	1	189412060	Kohlebürste	carbon brush
	1	189412061	Kohlebürste mit Meldelitze	carbon brush with wire
8	4	189622009	Federscheibe	spring washer
9	2	189622010	Gewindefurchschraube	self tapping screw
10	1	189502092	Seeger-Sprengring	circlip
11	1	189502011	Steckerbstift	tapered dowel pin
12	2	189502057	O-Ring	o-ring
13	4	189502073	Blechschaube	tapping screw
14	1	03200-023	Rillenkugellager	deep groove ball bearing
15	1	189502084	Getriebelagerschild	gearbox flange
16	1	189502088	Getriebegehäuse	gear box
17	1	189502017	Zwischenrad	intermediate gear
18	1	189502090	Welle mit 2 Ritzeln	shaft with 2 gears
19	1	189502091	Dichthülse	sealing sleeve
20	1	189502087	Wellendichtring	rotary shaft seal
21	1	189502021	Rillenkugellager	deep groove ball bearing
23	1	189502078	Arbeitsspindel	work spindle
31	1	189302020	Rillenkugellager	deep groove ball bearing
32	1	189502032	Spindelrad	spindle gear
33	1	189502033	Passfeder	feather key
34	1	189502034	Passscheibe	adjusting washer
35	1	189502035	Sicherungsring	retaining ring
36	1	189502036	Welle für Zahnradblock	shaft for cluster gear
37	1	189812011	Rillenkugellager	deep groove ball bearing
38	1	189502095	Zahnradblock	cluster gear
39	1	189622055	Passfeder	feather key
40	3	189601020	Nadelhülse	needle sleeve
42	1	189502061	Luftletring	fan shroud
43	2	189502043	Blechschaube	tapping screw
44	1	189502014	Feld kpl.	field cpl.
45	1	189502076	Motorgehäuse	motor housing
46	1	189502065	Entstörkondensator	anti-interference capacitor
49	1	189502096	O-Ring	o-ring
50	1	189411088	Schaltknopf	gear shift knob
51	1	189502098	Sicherungsring	retaining ring
52	1	189502099	Zylinderstift	dowel pin
53	1	189502100	Schaltbolzen	control pin
54	1	189502101	Rastbolzen	locking pin
55	1	189502102	Wellendichtung	rotary shaft seal